



DEAN FORGE  
handmade in Devon

# A family run business

Dean Forge was established by my father Michael Chew in 1969 in the hamlet of Dean Prior which nestles on the edge of Dartmoor.

In 1978, he designed and manufactured the first Dean Forge wood burning stove, the very local nature of this business was reflected in the name of the first range - Herrick Stoves after the poet Robert Herrick who lived in Dean Prior.

In 1994, we amalgamated our businesses and my father and I continued to develop and expand the range of wood and multi-fuel stoves. As we now enter our third generation, full of fresh and new ideas, I am confident that my daughter (Alice) and son-in-law (Jack) will push the business forward with the help and guidance from me, my Father and Pat a long-standing friend and manager of Dean Forge, allowing me to take a step back and focus on stove development and the manufacturing processes.

Luckily we have a dedicated established workforce who have vast expertise and experience in manufacturing and installing stoves. All our stoves are manufactured at Dean Forge in Devon with the doors cast in a British foundry.

We hope you enjoy perusing our collection of stoves on the following pages.

*Simon*

Simon Chew





CROFT SLIMLINE 5 ECO WITH A ROLLED EDGE TOP IN BLACK



SHERFORD SLIMLINE 5 ECO IN BLACK

# Choosing the right stove

Your stove will become the heart of your home. As well as being a key source of warmth, it becomes the very embodiment of comfort, ambience, and practicality. Selecting the right stove is a decision that extends beyond aesthetics, touching the core of efficiency, sustainability, and the overall atmosphere within your living space. As you navigate the different options available, understanding your needs is essential. Don't worry though - we have over 50 years of experience and are here to help you make the right decision.

-  Ecodesign compliant but NOT listed as DEFRA exempt.
-  Ecodesign compliant (e.g. previously SIA Ecodesign Ready) AND DEFRA exempt.
-  15% improvement on Ecodesign; AND DEFRA exempt.
-  15% improvement to emissions & efficiency performance on Level 4; AND DEFRA exempt.



Choose from Wood or Multi-fuel options - it's all about what fuel best suits your home and lifestyle.



The average heat production, measured in Kilowatts, indicating the nominal output. This figure is important when choosing the size of your stove.

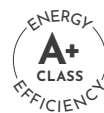

An assessment based on a scale indicating how well a stove converts fuel to usable heat energy. A+ being the most efficient, and G being the least.



The Stove's ability to convert fuel into heat, expressed as a percentage of total energy consumed. Anything over 80% is considered very good.



All our stoves are manufactured here in Britain.



We are a registered member of the SIA.

# Dartmoor Eco Range

## Traditional, classic, timeless.

A true embodiment of timeless tradition. Crafted with precision and care, these stoves seamlessly blend classic design with modern eco-friendly features. The Dartmoor Eco Range not only excels at efficiently heating your home but also adds a touch of elegance to your living space.

## Finish options

### COLOURS



BLACK



CHAMPAGNE



CHARCOAL



DORY BLUE



GREY



HONEY



FIRECRACKER



MOJAVE RED



MUSHROOM

### HANDLES



BLACK



STAINLESS  
STEEL

### AIR CONTROL



STAINLESS  
STEEL

## Key features

- Wood and multi-fuel options available on the whole range. Supplied as a woodburner or multi-fuel with option to convert to either a woodburner or multi-fuel at anytime
- Supplied with a black handle as standard
- Powerful preheated airwash system
- Independent primary and secondary air controls
- Top and rear flue outlets
- Tertiary air
- Can be fitted onto a non-structural hearth
- DEFRA exempt (approved for smoke controlled areas)
- Eco Design



DARTMOOR 5 ECO IN MOJAVE RED



# Dartmoor 5 Eco

- Only 130mm distance to combustibles to the rear when fitted with a double heat shield and twin wall flue
- Wood and multi-fuel options available on the whole range. Supplied as a woodburner or a multi-fuel with the option to convert to either a woodburner or multi-fuel at anytime if required
- Max log length 280mm

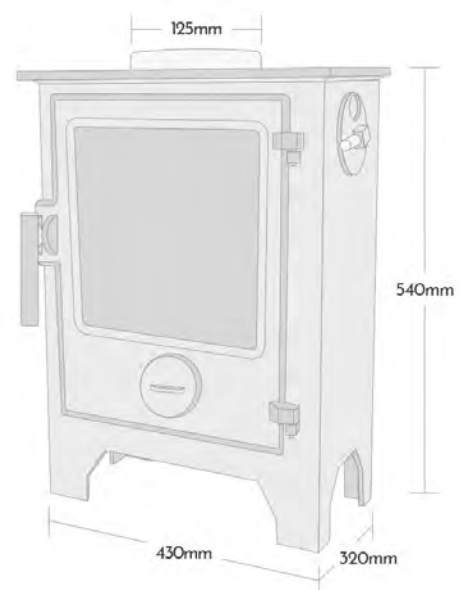

## MODELS



STANDARD



MIDI



HIGH





# Dartmoor W5 Eco

- Only 50mm distance to combustibles to the rear when fitted with a double heat shield and twin wall flue
- Wood and multi-fuel options available on the whole range. Supplied as a woodburner or a multi-fuel with the option to convert to either a woodburner or multi-fuel at anytime if required
- Max log length 380mm

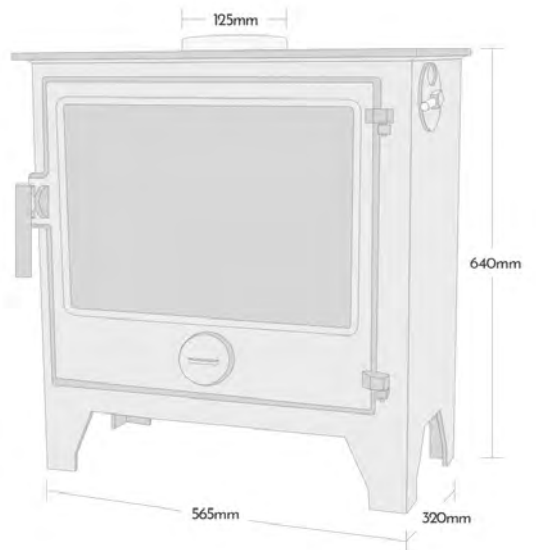

## MODELS



STANDARD



HIGH





FUEL  
WOOD  
OR  
MULTI  
TYPE

NOMINAL  
8kW  
OUTPUT

ENERGY  
A  
CLASS  
EFFICIENCY

EFFICIENCY  
80.1%  
RATING

## Dartmoor 8 Eco

- Only 150mm distance to combustibles to the rear when fitted with a double heat shield and twin wall flue
- Wood and multi-fuel options available on the whole range. Supplied as a woodburner or a multi-fuel with the option to convert to either a woodburner or multi-fuel at anytime if required
- Max log length 380mm

### MODELS



STANDARD



HIGH

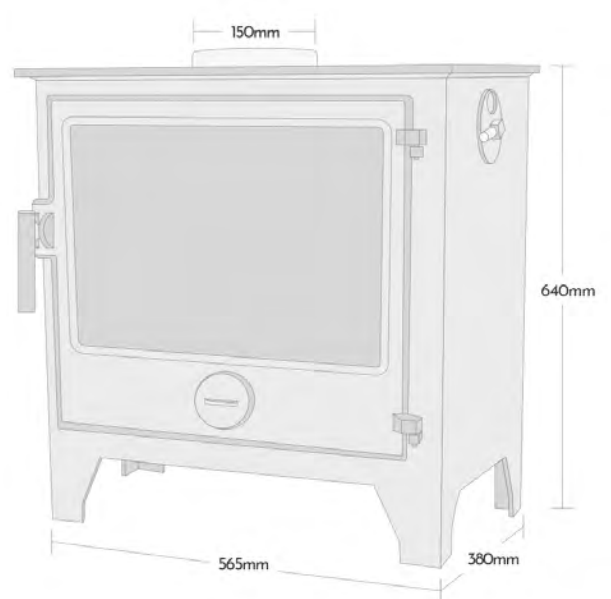

“I loved the Dean Forge  
Dartmoor so much I  
installed one in my own  
home – it turned a cold  
drafty room into the  
heart of our home.”

SIMON HARDING - FIREPLACES AND HEATING (LUTON)

# Dartmoor Baker Eco Range

## The stove that can do it all

Designed for versatility, this stove allows you to prepare your favourite meals while enjoying the incredible warmth and ambiance it provides. Perfect for shepherd's huts and open plan living spaces this multi-functional centrepiece brings both practicality and style to your home with modern eco-friendly features.

## Finish options

### COLOURS



BLACK



CHAMPAGNE



CHARCOAL



DORY BLUE



GREY



HONEY



FIRECRACKER



MOJAVE RED



MUSHROOM

### HANDLES

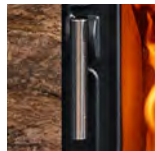

STAINLESS  
STEEL

### AIR CONTROL

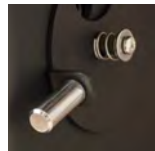

STAINLESS  
STEEL

### Oven Sizes

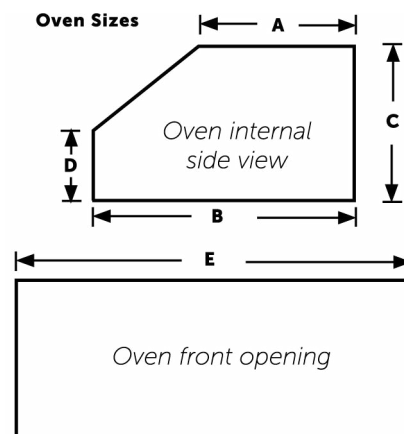

	MM				
	A	B	C	D	E
BAKER 5	160	210	150	100	278
BAKER W5	145	210	180	112	408
BAKER 8	182	255	180	112	408

## Key features

- Supplied as a woodburner or a multi-fuel with the option to convert to either a woodburner or multi-fuel at anytime if required
- Powerful preheated airwash system
- Independent primary and secondary air controls
- Top and rear flue outlets
- Tertiary air
- Can be fitted onto a non-constructural hearth
- DEFRA exempt (approved for smoke controlled areas)
- Eco Design
- Oven vents allow the cooking smells and condensation to be drawn out of the oven and up the chimney
- Rear flue outlet creates a clear area, providing extra space to access the hotter part of the top plate. Note a special Dartmoor Baker rear flue adaptor with flue cleaning access can be purchased to achieve this
- A removable cleaning plate is located inside the oven. This provides cleaning access to the top of the oven or for sweeping the chimney when fitted with a top exit flue
- All the Dartmoor Bakers can be manufactured with extended stove tops either side or on both sides. See individual product pages for more information



DARTMOOR BAKER 8 HIGH ECO IN DORY BLUE WITH EXTENDED TOP



# Dartmoor Baker 5 Eco

- Only 130mm distance to combustibles to the rear when fitted with a double heat shield and twin wall flue
- Wood and multi-fuel options available on the whole range. Supplied as a woodburner or a multi-fuel with the option to convert to either a woodburner or multi-fuel at anytime if required
- Extended Top available - Top width +120mm
- Max log length 280mm
- Oven size - see table on page 12

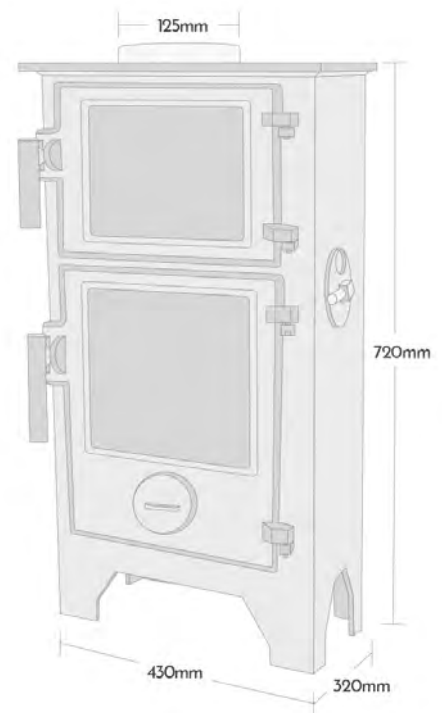

## MODELS



STANDARD



HIGH





# Dartmoor Baker W5 Eco

- Only 50mm distance to combustibles to the rear when fitted with a double heat shield and twin wall flue
- Wood and multi-fuel options available on the whole range. Supplied as a woodburner or a multi-fuel with the option to convert to either a woodburner or multi-fuel at anytime if required
- Extended Top available - Top width +150mm
- Max log length 380mm
- Oven size - see table on page 12

## MODELS



STANDARD



HIGH

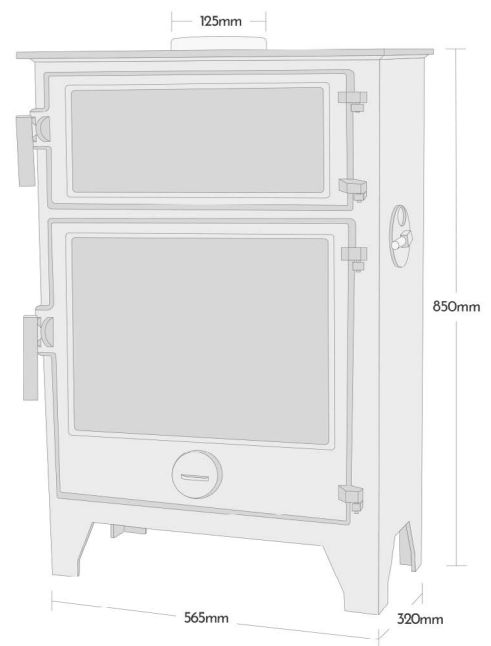



# Dartmoor Baker 8 Eco

- Only 150mm distance to combustibles to the rear when fitted with a double heat shield and twin wall flue
- Wood and multi-fuel options available on the whole range. Supplied as a woodburner or a multi-fuel with the option to convert to either a woodburner or multi-fuel at anytime if required
- Extended Top available - Top width +180mm
- Max log length 380mm
- Oven size - see table on page 12

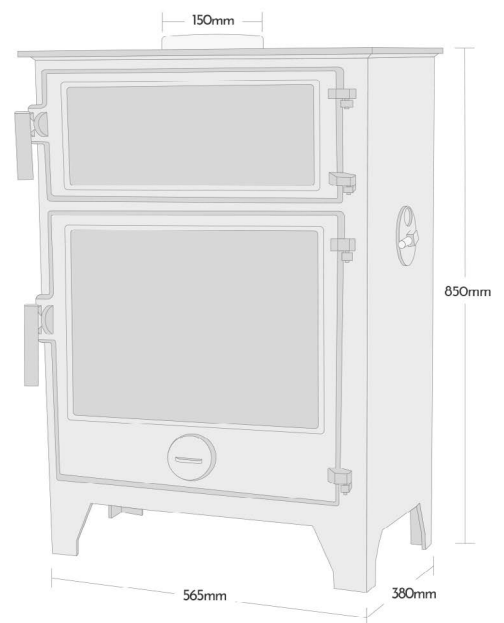

## MODELS



STANDARD



HIGH



“The Dean Forge Baker has been the best investment we’ve ever made. It’s perfect for cooking up a hearty winter stew, and it’s also great for keeping our dogs warm and cosy during the colder months. It’s a fantastic appliance that has become an essential part of our home”

MRS GARNER, EXMOOR

# Woodbury Eco Range

## A traditional stove with a modern feel

The Woodbury Eco Range not only delivers efficient heating but also brings a touch of sophistication to your living space. With its traditional charm seamlessly blended with a modern feel and eco-friendly features, this stove becomes a focal point that enhances the overall ambience of your home.

## Finish options

### COLOURS



BLACK

CHAMPAGNE

CHARCOAL

DORY BLUE

GREY

HONEY

FIRECRACKER

MOJAVE RED

MUSHROOM

### HANDLES



BLACK



STAINLESS  
STEEL

### AIR CONTROL

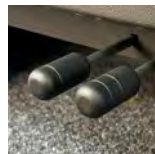

BLACK

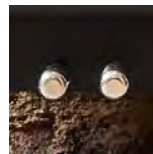

STAINLESS  
STEEL

## Key features

- Large glass doors
- Elegant robust legs
- Wood and multi-fuel options. The Woodbury range is not interchangeable once manufactured
- Exceptional preheated airwash system (see further information on page 38)
- Top and rear flue outlets
- Independent primary and secondary air controls
- Tertiary air
- Closed combustion option
- Can be fitted onto a non-constructural hearth
- DEFRA exempt (approved for smoke controlled areas)
- Eco Design
- Stainless steel handle and air controls as standard



WOODBURY 8 ECO IN BLACK



# Woodbury 5 Eco

- Only 100mm distance to combustibles to the rear when fitted with a double heat shield and twin wall flue
- Exceptional preheated airwash system (see further information on page 38)
- Independent primary and secondary air controls
- Max log length 330mm

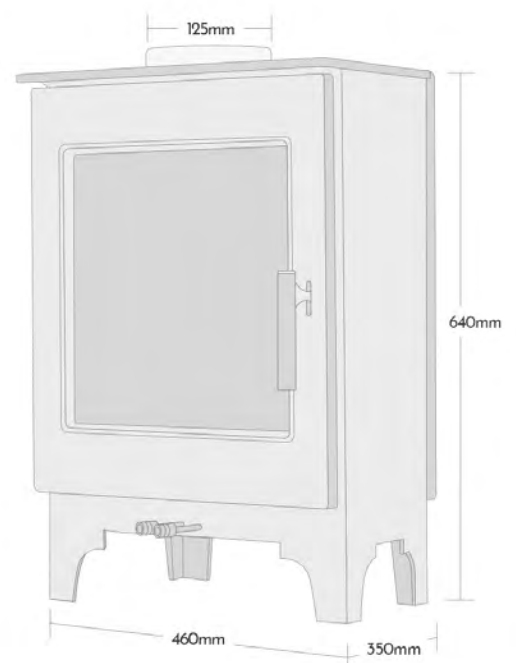



# Woodbury Slimline 5 Eco

- Only 150mm distance to combustibles to the rear when fitted with a double heat shield and twin wall flue
- Exceptional preheated airwash system (see further information on page 38)
- Independent primary and secondary air controls
- Max log length 400mm

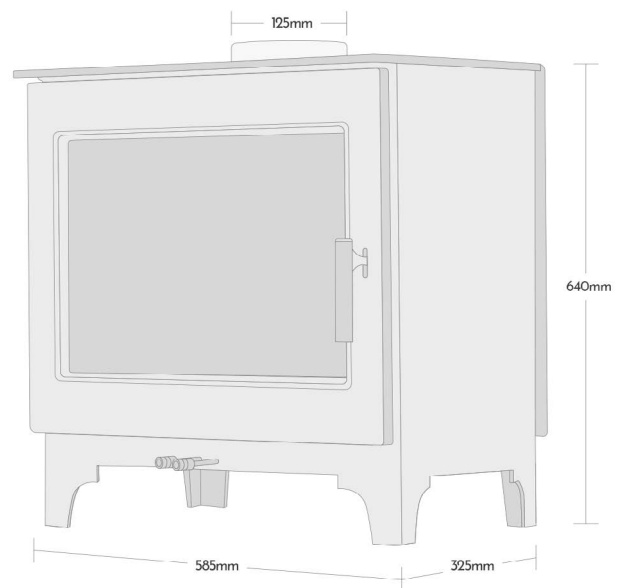



## Woodbury 8 Eco

- Only 170mm distance to combustibles to the rear when fitted with a double heat shield and twin wall flue
- Exceptional preheated airwash system (see further information on page 38)
- Independent primary and secondary air controls
- Max log length 400mm

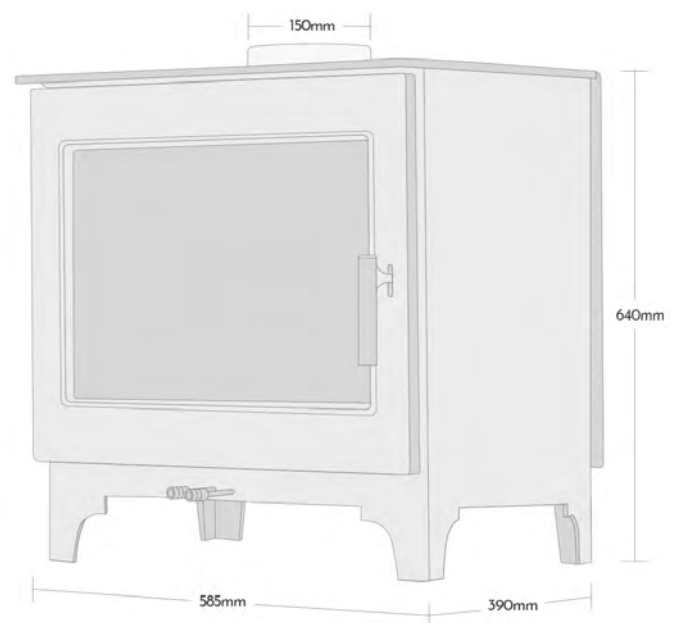



# Sherford Eco Range

## Sleek and contemporary for the modern home

With a streamlined and contemporary aesthetic, the Sherford Range brings a touch of sophistication to your home while providing exceptional heating performance with eco-friendly features. Its clean lines and contemporary finish make it the perfect addition to modern interiors, elevating the overall ambience with a minimalist yet stylish appeal.

## Finish options

### COLOURS



BLACK



CHAMPAGNE



CHARCOAL



DORY BLUE



GREY



HONEY



FIRECRACKER



MOJAVE RED



MUSHROOM

### HANDLES



BLACK

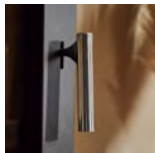

STAINLESS  
STEEL

### AIR CONTROL

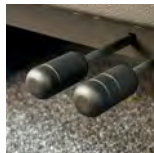

BLACK

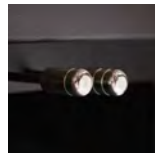

STAINLESS  
STEEL

## Key features

- Exceptional preheated airwash system (see further information on page 38)
- Top and rear flue outlets
- Tertiary air
- Closed combustion option
- Can be fitted onto a non-constructural hearth
- Independent primary and secondary air controls
- The Sherford range is a wood only stove
- Stainless steel handle and air controls as standard
- DEFRA exempt (approved for smoke controlled areas)
- Eco Design
- Plinth available for the Sherford 5, Slimline 5 and 8 - can be purchased with the stove or added at a later date



SHERFORD 8 ECO IN BLACK



# Sherford 5 Eco

- Only 100mm distance to combustibles to the rear when fitted with a double heat shield and twin wall flue
- Exceptional preheated airwash system (see further information on page 38)
- Independent primary and secondary air controls
- Max log length 330mm

## MODELS



STANDARD



HIGH

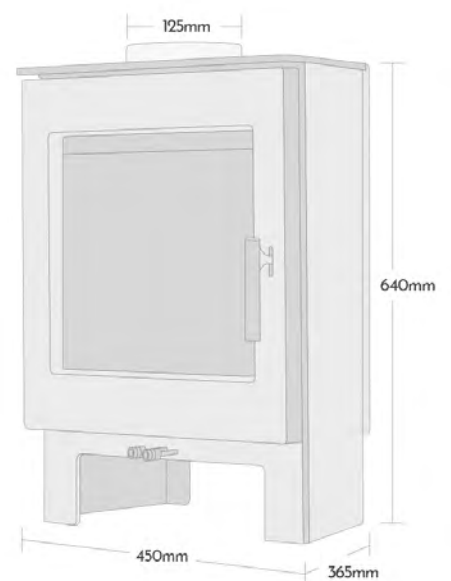



# Sherford Slimline 5 Eco

- Only 150mm distance to combustibles to the rear when fitted with a double heat shield and twin wall flue
- Exceptional preheated airwash system (see further information on page 38)
- Independent primary and secondary air controls
- Max log length 400mm

## MODELS



STANDARD



HIGH

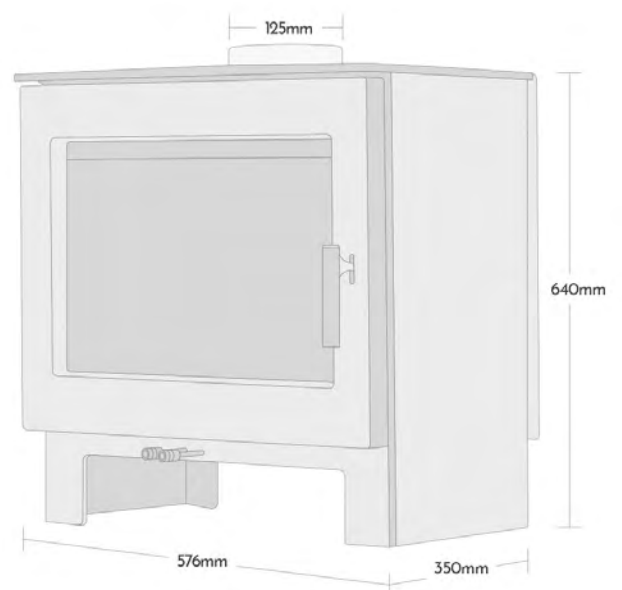



# Sherford 8 Eco

- Only 170mm distance to combustibles to the rear when fitted with a double heat shield and twin wall flue
- Exceptional preheated airwash system (see further information on page 38)
- Independent primary and secondary air controls
- Max log length 400mm

## MODELS



STANDARD



HIGH

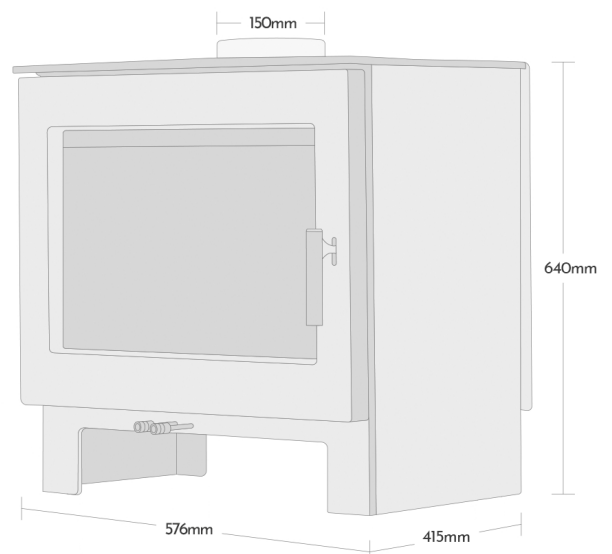

“Our Sherford Woodburner has been a wonderful addition to our home. With its simple controls and immediate response, it’s an absolute joy to use. Plus, the large glass makes it a very attractive centrepiece in our living room. I’d say the Sherford is definitely the heart of our home.”

A. HAYWARD, DEVON

# Croft Eco Range

## The classic: designed and first manufactured in 1978

A classic masterpiece that stands the test of time. First designed and manufactured in 1978, the Croft range will bring a sense of nostalgia and reliability to your home, but with all the modern eco-friendly features. Crafted with precision and care, this stove not only delivers exceptional heating performance but also serves as a testament to decades of expertise in the art of stove manufacturing.

## Finish options

### COLOURS

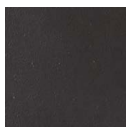

BLACK



CHARCOAL



GREY



HONEY

### TOPS



PROFILE



ROLLED EDGE

### HANDLES



BLACK



STAINLESS  
STEEL

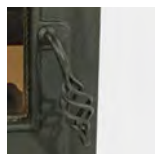

CAGE

### AIR CONTROL

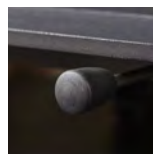

BLACK

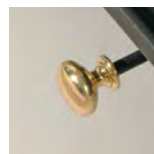

BRASS



STAINLESS  
STEEL

## Key features

- Exceptional preheated airwash system (see further information on page 38)
- Top and rear flue outlets
- Tertiary air
- Closed combustion option
- Double glazed glass door
- Can be fitted onto a non-constructural hearth
- Independent primary and secondary air controls
- The Croft range is a wood only stove
- Black handle and air control as standard
- DEFRA exempt (approved for smoke controlled areas)
- Eco Design
- Available with either a profile flat top or a rolled edge top



CROFT SLIMLINE 5 ECO WITH PROFILE TOP IN BLACK



## Croft Junior Eco

- Only 100mm distance to combustibles to the rear when fitted with a double heat shield and twin wall flue
- Exceptional preheated airwash system (see further information on page 38)
- Double glazed glass door
- Available with either a profile flat top or a rolled edge top
- Independent primary and secondary air controls
- Max log length 330mm

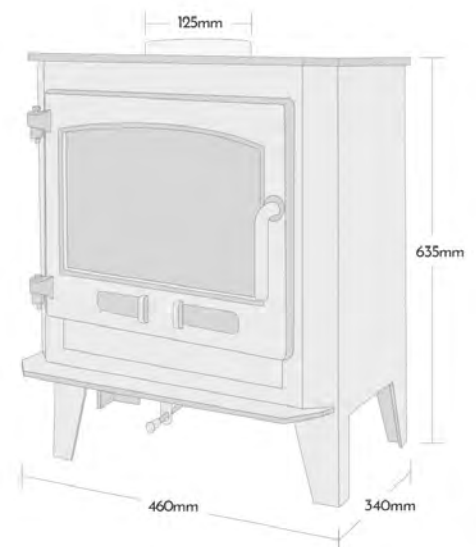



## Croft Slimline 5 Eco

- Only 150mm distance to combustibles to the rear when fitted with a double heat shield and twin wall flue
- Exceptional preheated airwash system (see further information on page 38)
- Double glazed glass door
- Available with either a profile flat top or a rolled edge top
- Independent primary and secondary air controls
- Max log length 400mm

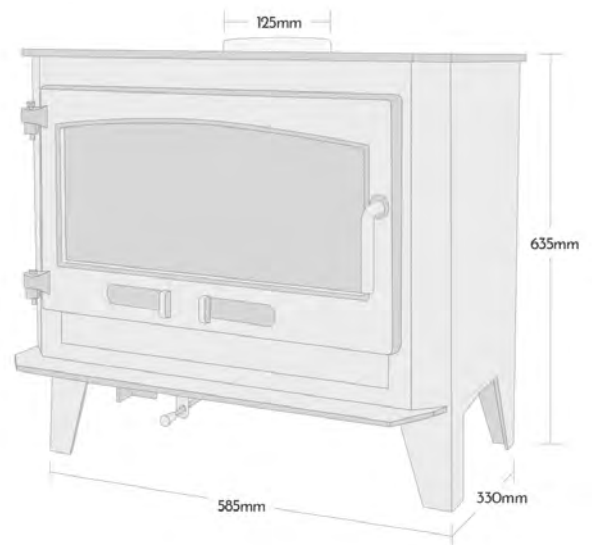



## Croft 8 Eco

- Only 170mm distance to combustibles to the rear when fitted with a double heat shield and twin wall flue
- Exceptional preheated airwash system (see further information on page 38)
- Double glazed glass door
- Available with either a profile flat top or a rolled edge top
- Independent primary and secondary air controls
- Max log length 400mm

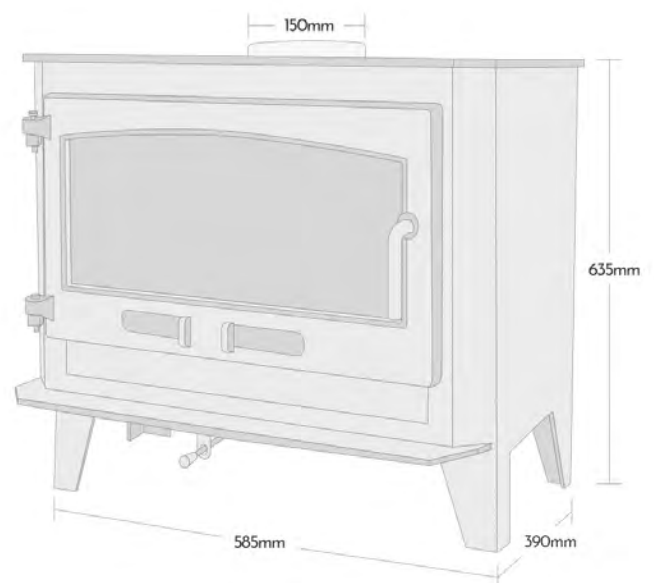



# 105 Eco Inset

## A window of flame

- Multi-fuel stove
- Double skin convector box to all sides of the fire box
- DEFRA exempt (approved for smoke controlled areas)
- Removable wood burning plate as standard
- Supplied with surround frame for wider fireplaces
- Tertiary air
- Max log length 250mm
- Large curved glass window
- Ducting is built into all sides of the fire box, encouraging cold air to be drawn into the underside of the stove, before being heated up through the ducting and naturally convected into the room through the top and side venting.
- The 105 inset stove is designed to be installed into a fireplace opening with the chair brick removed.
- Eco design

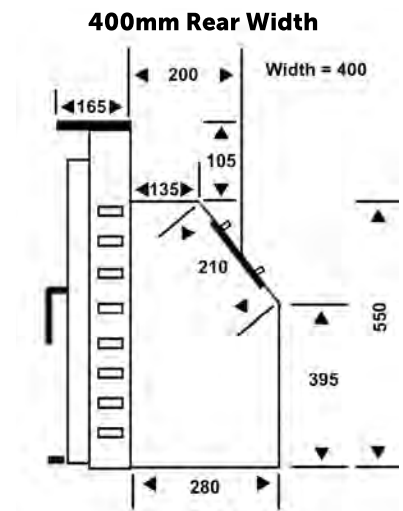



# DF Cool Wall

## Reduce your restrictions

Wood burning stoves have become increasingly efficient, designed to harvest the maximum energy from the fuel and distribute as much heat as possible into the room.

When it comes to installing wood or multi-fuel stoves these materials are often flammable making it unsafe and illegal to install a stove in front or to the side. All CE tested and approved stoves will have gone through an over-fire test, often bringing the stove to a point where it will glow red hot. This test will determine how far from combustible materials the stove can be installed. Some stove companies will restrict the primary and secondary combustion air to reduce the heat produced on this test, but this can impede the performance of the stove.

Dean Forge do not restrict the combustion air and have developed the DF Cool Wall. Under test the DF Cool Wall recorded temperatures of more than 600°C behind the stove with a rise in room temperature behind the DF Cool Wall of only 4°C.

The DF Cool Wall comes in three different sizes and high temperature black.

Please note: A Dean Forge Stove can be installed 50mm away from DF Cool Wall with a combustible wall behind.

**SMALL** 750mm (Width) x 800mm (Height), 80mm (Depth)

**MEDIUM** 900mm (Width) x 1100mm (Height), 80mm (Depth)

**LARGE** 1200mm (Width) x 1100mm (Height), 80mm (Depth)



SHERFORD 5 ECO IN BLACK WITH PLINTH ON A DF MEDIUM BENCH

# Dean Forge Bench

## Elevate your stove

The perfect addition to elevate Dean Forge stoves. With an optimal height, this bench provides an unparalleled viewing experience. Not only that, it also doubles as a convenient storage space for firewood, keeping everything required close at hand. Crafted from high quality steel and finished with a stylish matt black coating, this bench is the perfect complement to the Dean Forge range.

- Flat Black
- Can be used for all our stove ranges
- Normal hearth requirements required

### **SIZES AVAILABLE**

450mm (Width) x 350mm (Height), 450mm (Depth)

900mm (Width) x 350mm (Height), 450mm (Depth)

1200mm (Width) x 350mm (Height), 450mm (Depth)

# Further information

**Colour of stoves** All heat resistant paint will change colour shades when the stove is put under fire and the paint is fully cured. Some of the lighter colours will noticeably vary in shade where the stove naturally has cooler areas. Due to the limitations of the print process actual colours may vary from photographed.

**Airwash systems** All Dean Forge stoves incorporate a preheated airwash system. This system takes the cold air either from the bottom or the side of the stove and heats it to a high temperature via a labyrinth of passages before being drawn over the glass door. This drives unburnt gases back into the fire chamber whilst mixing with the air at the same time. These gases combined with the hot air cause combustion over the glass, burning more fuel particles and unwanted deposits on the glass, increasing the efficiency and vision of the fire.

The Woodbury, Sherford and Croft ranges have an Airwash system which is unlike many other stoves on the market. Secondary air is taken through the base of the stove where it starts to absorb heat. It then travels through special air ducts at the back of the stove where it takes on more heat. At this point some of the air is directed through the airways in the back of the stove above the flames to ignite unburnt gases and reduce particles. The remaining air is heated further and drawn over the glass to burn off unwanted deposits. It continues to the fire bed supplying air to the burning fuel.

## Hearth requirements and stove installation

All Dean Forge stoves built after February 2022 are able to be installed on a minimum of 12mm non-combustible hearth to meet current building regulations. Please refer to installation instructions and current building regulations before installing your stove. Dean Forge recommend all stove installations are carried out by an experienced qualified engineer.

**Fuel** All stoves will burn wood and brickettes. Stoves fitted with multi-fuel grates will burn all types of smokeless fuel recommended for enclosed appliances. As with all wood burning stoves the wood you burn must have a moisture content of less than 20%. It is imperative that the wood you use is kiln dried or has been air dried for at least one year in a covered position before being used on any stove.

**Closed combustion** The Croft, Sherford and Woodbury ranges can be fitted with a direct air manifold enabling combustion air to be connected directly to an outside air source. By using the closed combustion system you prevent the stove from stealing heat from the room thus maximising the heat efficiency of the stove.

**Flue options** There are three flue arrangements available – top, rear and back box. Top and rear flue options are fitted as standard on all Dean Forge stoves. This is achieved by moving the interchangeable flue spigot and cover plate to either the top or the back. The back box is an optional extra. This is fixed to the back outlet on the stove, using the same fixing point as the standard spigot, and enabling the stove to be brought forward in the fireplace and the top kept clear, whilst using a vertical flue. This option also eliminates the use of a tee and cap, with the added facility in most cases to still clean the flue through the stove.

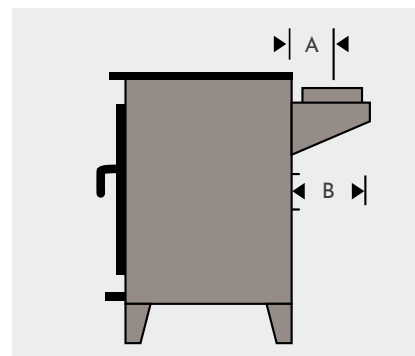
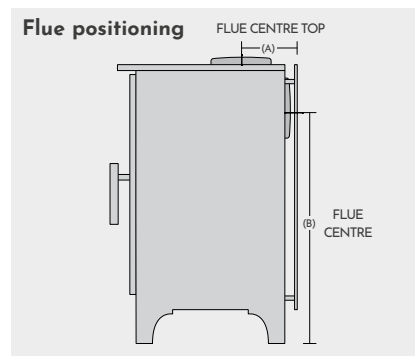

**125mm Outlet:** Dimension A - 90mm, Dimension B - 180mm  
**150mm Outlet:** Dimension A - 105mm, Dimension B - 210mm

**Calculating your heat requirement** A good guide to calculate the heat requirement of a given room is:

$$H \times W \times D \text{ (ft)} \div 500 \text{ (} H \times W \times D \text{ (m)} \div 14)$$

This gives you the kilowatt requirement. This is based on average house insulation with room temperatures of 20°C and an ambient temperature of -1°C. Well-insulated houses could replace the division of 500 with 650.

**Your guarantee** Dean Forge Fabrications Ltd offers a five year guarantee which covers the main body of the stove for manufacturing defects.

Dean Forge has a policy of continuous development and reserves the right to change the specification on the stoves without further notice. The illustrations in this brochure do not necessarily comply with local building regulations. Coloured flue not supplied, for photo purposes only. Due to the limitations of the print process actual colours may vary.

OUTPUT AND EFFICIENCY				STOVE DIMENSIONS (MM)										DISTANCE TO COMBUSTIBLES (MM)		
NOMINAL STOVE OUTPUT	ENERGY EFFICIENCY CLASS	EFFICIENCY (%)	WIDTH	HEIGHT	DEPTH O/A	DEPTH WITH HANDLE	DEPTH WITH DOUBLE REAR HEAT SHIELD	LEG LENGTH	FLUE SIZE	FLUE CENTRE TOP (A)	FLUE CENTRE (B)	REAR OF STOVE	WITH DOUBLE REAR HEAT SHIELD (AND TWIN WALL FLUE)	SIDE OF STOVE	ABOVE STOVE	
<b>DARTMOOR</b>																
5 ECO	A+	82.1	430	540 (STD) 690 (MID) 785 (HIGH)	320	375	335	50 (STD) 200 (MID) 300 (HIGH)	125	133	438 (STD) 588 (MID) 688 (HIGH)	150	130	550	—	
W5 ECO	A+	83.1	565	640 (STD) 785 (HIGH)	320	375	335	105 (STD) 250 (HIGH)	125	133	475 (STD) 620 (HIGH)	200	50	350	—	
8 ECO	A	80.5	565	640 (STD) 785 (HIGH)	380	435	395	105 (STD) 250 (HIGH)	150	150	475 (STD) 620 (HIGH)	300	150	350	—	
BAKER 5 ECO	A+	82.1	430	720 (STD) 900 (HIGH)	320	375	355	50 (STD) 230 (HIGH)	125	133	618 (STD) 797 (HIGH)	150	130	550	—	
BAKER W5 ECO	A+	83.1	565	850 (STD) 1000 (HIGH)	320	375	335	105 (STD) 255 (HIGH)	125	133	748 (STD) 898 (HIGH)	200	50	350	—	
BAKER 8 ECO	A	80.5	565	850 (STD) 1000 (HIGH)	380	435	395	105 (STD) 255 (HIGH)	150	150	735 (STD) 885 (HIGH)	300	150	350	—	
<b>WOODBURY</b>																
5 ECO	A+	82.4	460	640	350	400	365	95	125	135	490	200	100	400	—	
SLIMLINE 5 ECO	A+	81.4	585	640	325	375	340	95	125	135	490	250	150	500	—	
8 ECO	A	75.1	585	640	390	440	405	95	150	145	495	300	170	400	—	
<b>SHEREFORD</b>																
5 ECO	A+	82.4	450	640 (STD) 810 (HIGH)	365	415	380	100 (STD) 170 (HIGH)	125	135	495	200	100	400	—	
SLIMLINE 5 ECO	A+	81.4	576	640 (STD) 810 (HIGH)	350	400	365	100 (STD) 170 (HIGH)	125	135	495	250	150	500	—	
8 ECO	A	75.1	576	640 (STD) 810 (HIGH)	415	465	430	100 (STD) 170 (HIGH)	150	145	500	300	170	400	—	
<b>CROFT</b>																
JUNIOR ECO	A+	82.4	460 (FLAT) 490 (ROLLED)	635	340	395	355	100	125	135	490	200	100	400	—	
SLIMLINE 5 ECO	A+	81.4	585 (FLAT) 622 (ROLLED)	635	330	385	345	100	125	135	490	250	150	500	—	
8 ECO	A+	75.1	585 (FLAT) 622 (ROLLED)	635	390	465	405	100	150	145	500	300	170	300	—	
<b>INSET</b>																
105 ECO INSET	A	78	455 (STD) 495 (W/SURROUND)	655	450	—	—	—	125	—	—	—	—	200	400	



**DEAN FORGE**  
handmade in Devon

GENERAL ENQUIRIES: [STOVES@DEANFORGE.CO.UK](mailto:STOVES@DEANFORGE.CO.UK) | TRADE ENQUIRIES: [SALES@DEANFORGE.CO.UK](mailto:SALES@DEANFORGE.CO.UK)

DEAN PRIOR, BUCKFASTLEIGH, DEVON, TQ11 0LS  
01364 643574